

# CLARKE<sup>®</sup>

## INTERNATIONAL

### Tungsten Grit Hole Saw Set

CLARKE core drills are vibrationless when used as directed.

Core drills are used to form holes in ceramic tiles, plastic, plywood and aerated concrete blocks.

A heavy duty drill with adjustable speed control and high torque must be used with hole saws.

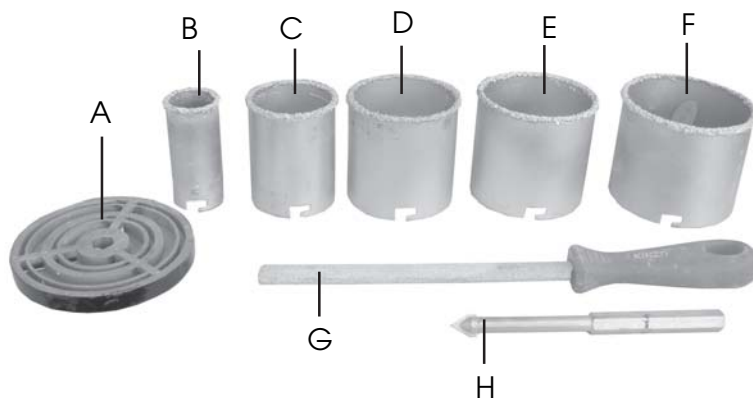

- A Bayonet Mandrel
- B 33mm Hole saw (max -1500 rpm)
- C 53mm Hole saw (max -1500 rpm)
- D 67 mm Hole saw (max -700 rpm)
- E 73 mm Hole saw (max -700 rpm)
- F 83 mm Hole saw (max - 700 rpm)
- G Carbide Gritted File
- H Carbide Tipped Pilot Drill

1. Insert the pilot drill into the mandrel as shown, tighten the screw on the mandrill to hold the pilot drill in place.

■ Do not overtighten the screw.

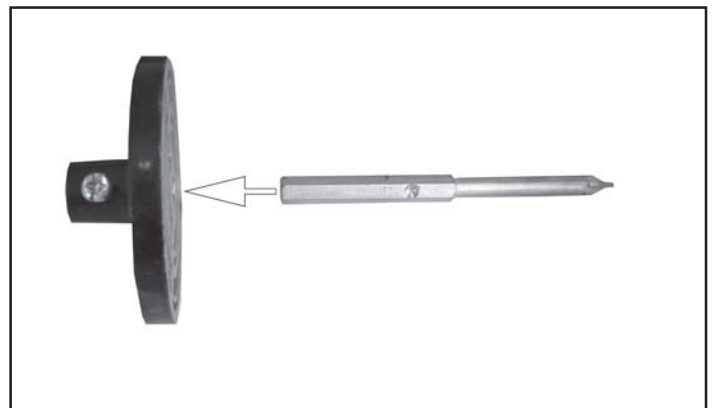

2. Hook the required hole saw onto the mandrel.



# SAFETY PRECAUTIONS

For your own safety and that of others around you, please read and observe these safety instructions.

1. **ALWAYS** learn the specific hazards relating to the tool you are using. Read all operating instructions.
2. **ALWAYS** wear good quality industrial gloves.
3. **ALWAYS** wear safety goggles, manufactured to the latest European Safety Standards. Everyday eyeglasses do not have impact resistant lenses, they are not safety glasses.
4. **ALWAYS** wear a suitable dust mask.
5. **ALWAYS** check for damage. Before using the machine, any damaged part, should be properly repaired or the part replaced. If in doubt, **DO NOT** use and consult your local dealer.
6. **ALWAYS** keep work area clean. Cluttered areas invite accidents.
8. **ALWAYS** ensure that adequate lighting is available. Ensure that lighting is placed so that you will not be working in your own shadow.
9. **ALWAYS** keep children away. All visitors should be kept a safe distance from the work area, especially whilst operating the machine.
10. **ALWAYS** maintain machine in top condition. Keep tools clean for the best and safest performance.
11. **ALWAYS** concentrate on the job in hand, no matter how trivial it may seem. Be aware that accidents are caused by carelessness due to familiarity.
12. **ALWAYS** keep your proper footing and balance at all times. Don't overreach. For best footing, wear rubber soled footwear, keep floor clear of oil, scrap wood, etc.

## Directions For Use

1. **ALWAYS** drill a 8mm pilot hole before attempting to use the hole saw .
2. Assemble the hole saw as directed on the previous page.
3. Insert assembled hole saw into the drill chuck and tighten securely.
4. Set the drill to a reasonably slow speed, plug in and switch ON.
5. Slowly offer the pilot drill into pre-drilled hole, use steady pressure to push the hole saw into the surface of the material. **DO NOT FORCE** the drill, allow the drill to do the work.  
It may be necessary to adjust the speed of the drill to suit the size of the hole saw being used.
6. To ensure the hole saw doesn't bind, occasionally withdraw it from the hole whilst it is still turning to clear any waste, keep repeating this process until the hole is finished.
7. When finished turn the drill OFF and unplug from the main electric supply.

### !!! CAUTION !!!

When using hole saws, make sure that you have a firm grip at all times to prevent the drill being snatched from your hands in the event of a jam. Jamming can be caused for various reasons, such as small pieces of material breaking off and wedging the hole saw in the hole.

## CLARKE GUARANTEE

This CLARKE product is guaranteed against faulty manufacture for a period of 12 months from the date of purchase. Please keep your receipt as proof of purchase.

This guarantee is invalid if the product is found to have been abused or tampered with in any way, or not used for the purpose for which it was intended.

Faulty goods should be returned to their place of purchase, no product can be returned to us without prior permission.

This guarantee does not effect your statutory rights.